

Brio® Wardrobe Roll Trio 50

Pack components

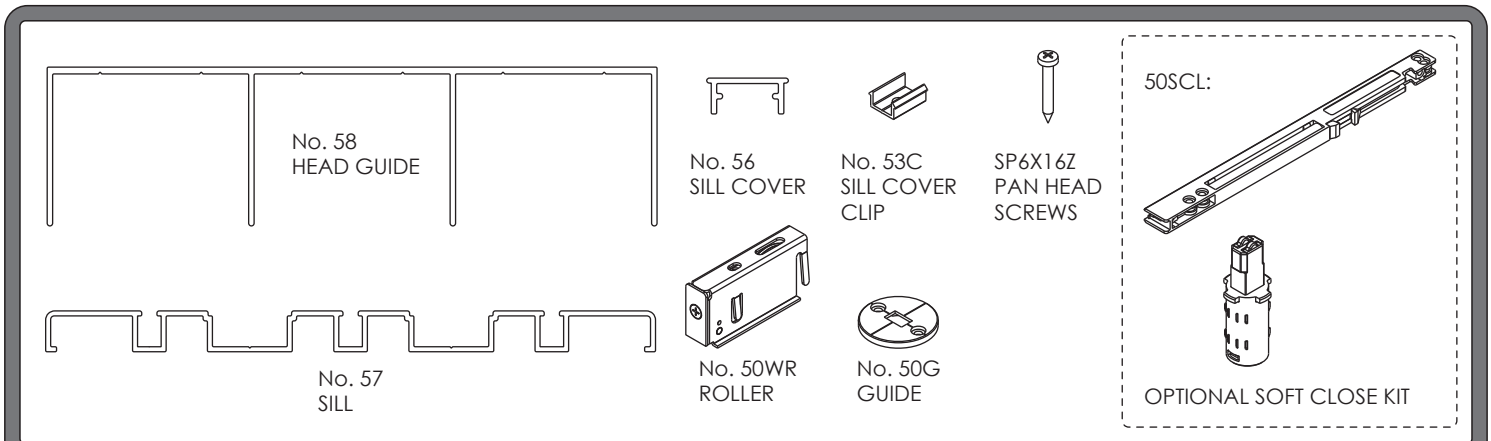

PACKS

	55	53	56	53C	SP6X16Z	50G	50WR	50WR-S	50WR-C
WT50-18/3*	x1(1800)	x1(1800)	x1(1800)	x6	x30	x6	x6		
WT50-21/3*	x1(2100)	x1(2100)	x1(2100)	x7	x33	x6	x6		
WT50-24/3*	x1(2400)	x1(2400)	x1(2400)	x8	x36	x6	x6		
WT50-27/3*	x1(2700)	x1(2700)	x1(2700)	x9	x41	x6	x6		
WT50S-18/3*	x1(1800)	x1(1800)	x1(1800)	x6	x42	x6	x6	x6	x6
WT50S-21/3*	x1(2100)	x1(2100)	x1(2100)	x7	x45	x6	x6	x6	x6
WT50S-24/3*	x1(2400)	x1(2400)	x1(2400)	x8	x48	x6	x6	x6	x6
WT50S-27/3*	x1(2700)	x1(2700)	x1(2400)	x9	x50	x6	x6	x6	x6

*Aluminium finishes: BA = black anodised, CA = clear anodised, PWT = powder coat white

Head and gill preparation head, sill and sill cover cut to length 'W' (finished opening width)

Screw fixings to be staggered along length, avoiding 257mm from ends of head guide if using soft close

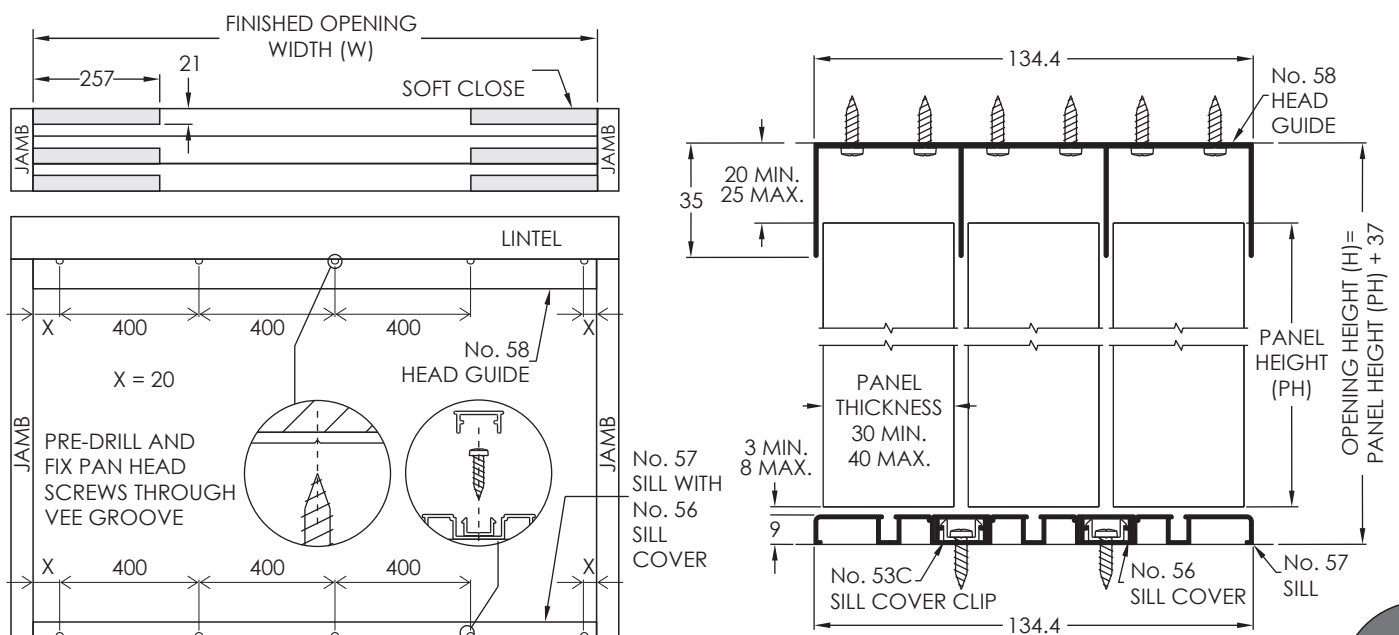

Panel preparation and hardware installation

Panel height = Opening height - 37mm
 3 panels: Panel width = (Opening width / 3) + 20mm (overlap)

Install panels as per numbered sequence below

3 PANEL CONFIGURATION

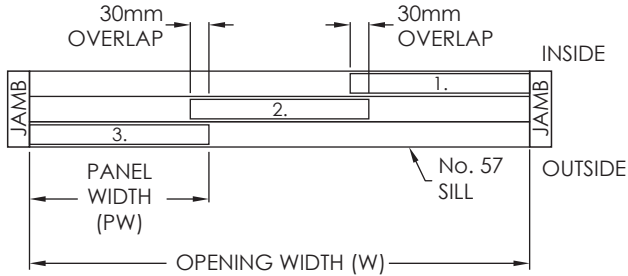

Machine slot and drill adjustment hole for No. 50WR Roller

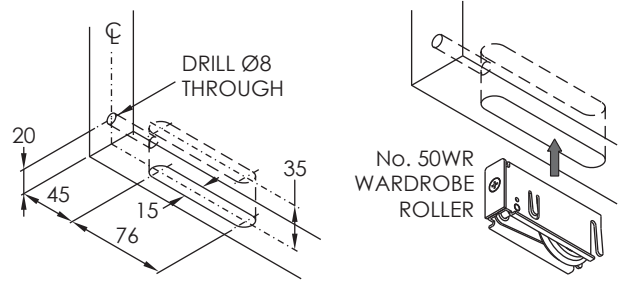

Pre-drill holes for No. 50 Guide

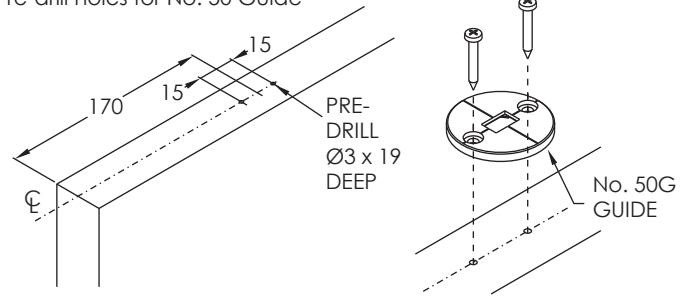

Fitting soft close (optional)

Prepare panels as shown and fit components. Fit soft close into No. 55 head guide using fixings supplied.

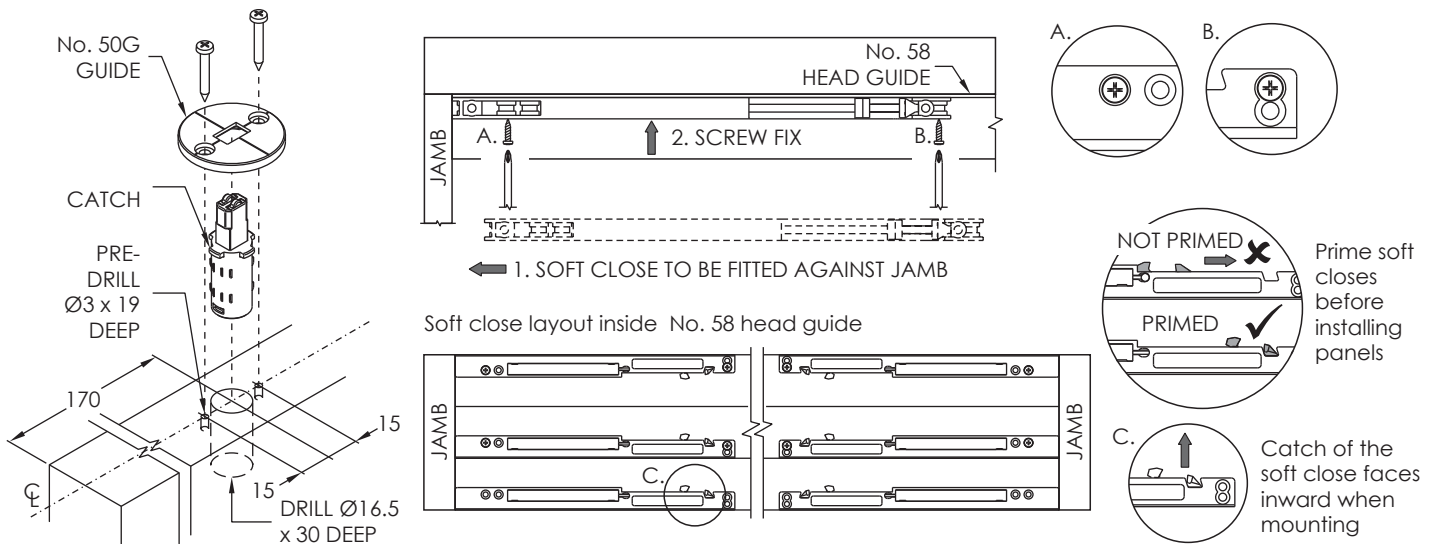

Fitting panels

Adjust rollers up prior to installation.

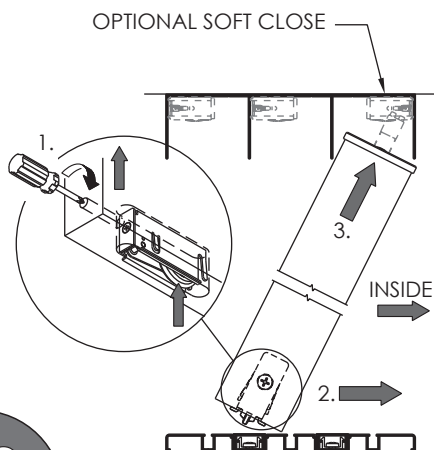

Soft close catch does not need to align to soft close yet. Repeat the process for the outside panel

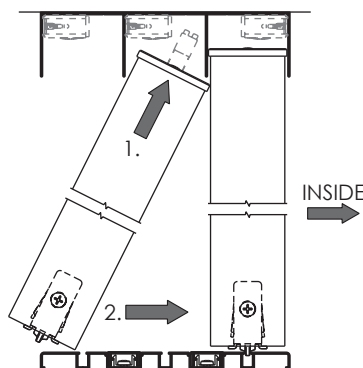

Do not slide panel until rollers have been adjusted down. Test panels.

